

電着工具 Electroplated tool

電着汎用製品 Electroplated general-purpose product IV series

IV SERIES

手仕上げからマシニングセンタやジグボアなどの高精度加工まで幅広くご使用いただけます。

This series can be used for various purposes such as finishing by hand, highly accurate processing by machining centers and jig boring machines.

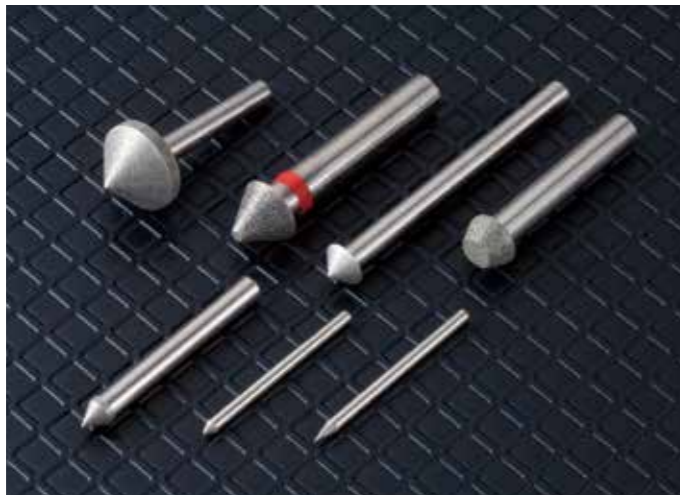

面取り用 IVシリーズ IV series for chamfering

面取りやセンタ穴の加工に最適です。

Perfect for the chamfering and the processing of center holes.

形状 Dimensions

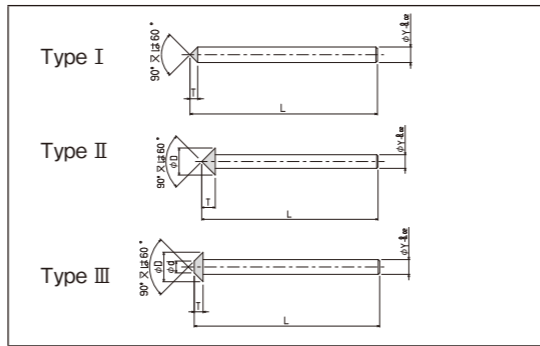

品番 Product No.	名称 Product name	Type	外径 φD Diameter	角度 Angle	先端φ小径 φd Tip fat diameter	シャンク径 φY Shank diameter	全長 L Body length	母材材質 Metal core material	粒度 ダイヤモンド Granularity Diamond
IVD-3.60	φ3.0先端角60° φ3.0 tip angle 60°	Type I	3.0	60	—	3.0	40	ピアノ線 Piano wire	#140
IVD-3.90	φ3.0先端角90° φ3.0 tip angle 90°		3.0	90	—	3.0	40		#140
IVD-6.60	φ6.0先端角60° φ6.0 tip angle 60°	Type II	6.0	60	—	3.0	70	SK材 SK	#120
IVD-6.90	φ6.0先端角90° φ6.0 tip angle 90°		6.0	90	—	3.0	70		#120
IVD-10.60	φ10.0先端角60° φ10.0 tip angle 60°	Type II	10.0	60	—	6.0	100		#120
IVD-10.90	φ10.0先端角90° φ10.0 tip angle 90°		10.0	90	—	6.0	100		#120
IVD-13.60	φ13.0先端角60° φ13.0 tip angle 60°	Type III	13.0	60	4	10.0	100		#120
IVD-13.90	φ13.0先端角90° φ13.0 tip angle 90°		13.0	90	4	10.0	100		#120
IVD-16.60	φ16.0先端角60° φ16.0 tip angle 60°	Type III	16.0	60	4	10.0	100		#120
IVD-16.90	φ16.0先端角90° φ16.0 tip angle 90°		16.0	90	4	10.0	100		#120
IVD-25.60	φ25.0先端角60° φ25.0 tip angle 60°	Type III	25.0	60	6	12.0	120		#120
IVD-25.90	φ25.0先端角90° φ25.0 tip angle 90°		25.0	90	6	12.0	120		#120

品番 Product No.	名称 Product name	Type	外径 φD Diameter	角度 Angle	先端φ小径 φd Tip fat diameter	シャンク径 φY Shank diameter	全長 L Body length	母材材質 Metal core material	粒度 CBN Granularity CBN
IVB-3.60	φ3.0先端角60° φ3.0 tip angle 60°	Type I	3.0	60	—	3.0	40	ピアノ線 Piano wire	#140
IVB-3.90	φ3.0先端角90° φ3.0 tip angle 90°		3.0	90	—	3.0	40		#140
IVB-6.60	φ6.0先端角60° φ6.0 tip angle 60°	Type II	6.0	60	—	3.0	70	SK材 SK	#120
IVB-6.90	φ6.0先端角90° φ6.0 tip angle 90°		6.0	90	—	3.0	70		#120
IVB-10.60	φ10.0先端角60° φ10.0 tip angle 60°	Type II	10.0	60	—	6.0	100		#120
IVB-10.90	φ10.0先端角90° φ10.0 tip angle 90°		10.0	90	—	6.0	100		#120
IVB-13.60	φ13.0先端角60° φ13.0 tip angle 60°	Type III	13.0	60	4	10.0	100		#120
IVB-13.90	φ13.0先端角90° φ13.0 tip angle 90°		13.0	90	4	10.0	100		#120
IVB-16.60	φ16.0先端角60° φ16.0 tip angle 60°	Type III	16.0	60	4	10.0	100		#120
IVB-16.90	φ16.0先端角90° φ16.0 tip angle 90°		16.0	90	4	10.0	100		#120
IVB-25.60	φ25.0先端角60° φ25.0 tip angle 60°	Type III	25.0	60	6	12.0	120		#120
IVB-25.90	φ25.0先端角90° φ25.0 tip angle 90°		25.0	90	6	12.0	120		#120

電着汎用製品 Electroplated general purpose product IVR series

IVR SERIES

電動グラインダーやエアグラインダーなどを使用した面取り加工やバリ取り加工に最適です。

Most recommendable diamond tool to be used with Grinding Tools for the Deburring or Chamfering process.



電動・エアグラインダー用 IVRシリーズ IVR series for grinding tools

形状 Dimensions

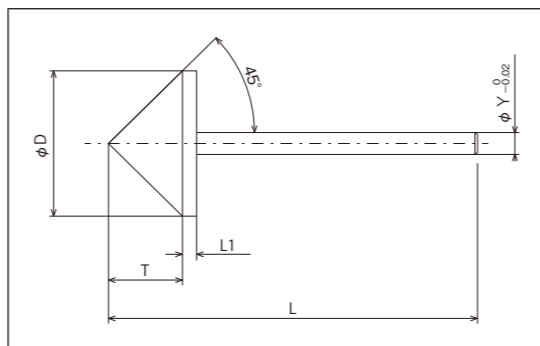

品番 Product No.	名称 Product name	外径 φD Diameter	角度 Angle	電着長 T Electroplated length	ストレート L1 Straight part length	全長 L Body length	シャンク径 φY Shank diameter	母材材質 Metal core material	粒度 ダイヤモンド Granularity Diamond
IVR-5.90	φ5先端角90° φ5 tip angle 90°	5	90	1.5	1	60	3	SK材 SK	#120
									#230
									#400
IVR-10.90	φ10先端角90° φ10 tip angle 90°	10	90	5	1	60	3		#120
									#230
									#400
IVR-15.90	φ15先端角90° φ15 tip angle 90°	10	90	3	1	60	3		#120
									#230
									#400
IVR-20.90	φ20先端角90° φ20 tip angle 90°	10	90	3	2	60	3		#120
								#230	
								#400	
IVR-25.90	φ25先端角90° φ25 tip angle 90°	10	90	3	2	60	3	#120	
								#230	
								#400	
IVR-30.90	φ30先端角90° φ30 tip angle 90°	10	90	3	2	60	3	#120	
								#230	
								#400	

電着ホイール Electroplated wheel IW series

IW SERIES

複雑な形状の高品質なホイールを短納期・低価格でご提供いたします。一般焼成砥石のツルイングや総形の研削加工にご使用いただけます。

We can provide intricately shaped, high-quality wheels with short delivery dates and low prices. These wheels can be used for the tooling of conventional abrasive wheels and the form grinding process.



製作可能範囲 Available Manufacturing

品番 Product No.	外径φD Diameter
IWD(ダイヤモンド) / IWB(CBN)切断加工用 diamond For cutting	~450
IWD(ダイヤモンド) / IWB(CBN)溝入加工用 diamond For grooving	~450
IWD(ダイヤモンド) / IWB(CBN)総形加工用 diamond For forming	~350

※範囲外につきましてもご相談ください。
※Please contact us regarding other sizes.

切断加工用 IWシリーズ IW series for cutting

セラミックス、超硬などの難削材や鋳鉄、焼入れした鉄系金属の切断加工が高精度・高能率に行えます。

Difficult-to-machine materials such as ceramics, tungsten carbides, cast iron, and hardened steel can be cut efficiently with a high degree of accuracy.

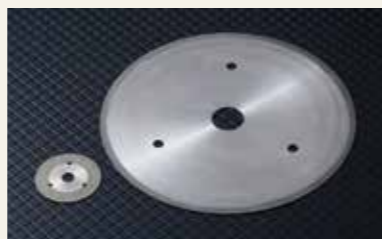

セラミックスの切断加工
Cutting of ceramics

溝入れ加工用 IWシリーズ IW series for grooving

エッジ部の形崩れが少ないのが特長です。

Provides processing with almost no edge deformation.



特殊ピンの溝入加工
Grooving of special pin

総形加工用 IWシリーズ IW series for forming

複雑な形状が製作でき変形も少ないので、量産加工において仕上り精度が安定しています。

Accurate and stable finishing for mass production that can handle intricate shapes with almost no deformation.

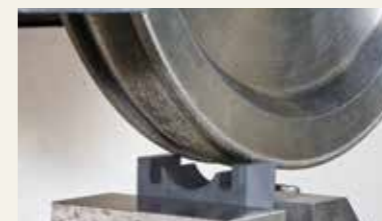

カーボンの総形加工
Forming of carbon

IWシリーズは受注生産品です。IW series is made up of special order items.

軽量化のためアルミ母材での製作も受け賜っております。
To reduce weight of wheel, aluminum core type can be made.

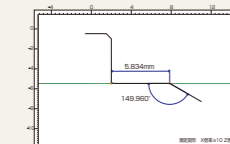

徹底した品質管理
Complete quality control

電着前後で測定し高品質の製品のみをご提供いたします。
We make measurements before and after electroplating to ensure product quality.